



LadyShip

生機博士®

貴夫人®

全營養調理機

NUTRITION RESERVED FOOD PROCESSOR

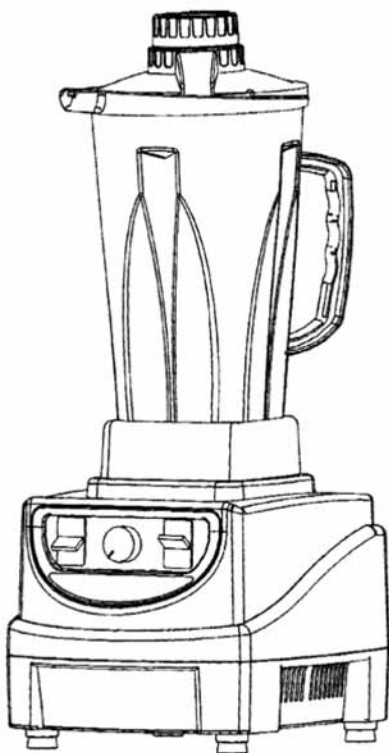

操作使用說明書

INSTRUCTION MANUAL

MODEL: LVT-866

內 容：

各部名稱及規格.....	1
安裝方法及安裝圖示.....	2
操作模式.....	3
面板圖示.....	4
注意事項.....	5
保養事項.....	6
使用須知.....	7
NAME / SPECIFICATION	8
ASSEMBLY / OPERATION.....	9
OPERATION.....	10
CONTROL PANEL.....	11
IMPORTANT SAFEGUARDS.....	12
MAINTENANCE / CLEANING.....	13
PROPER USE.....	14

各部名稱：

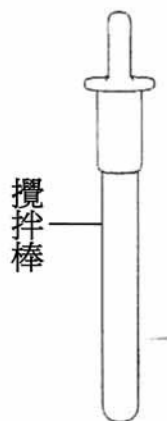

攪拌棒

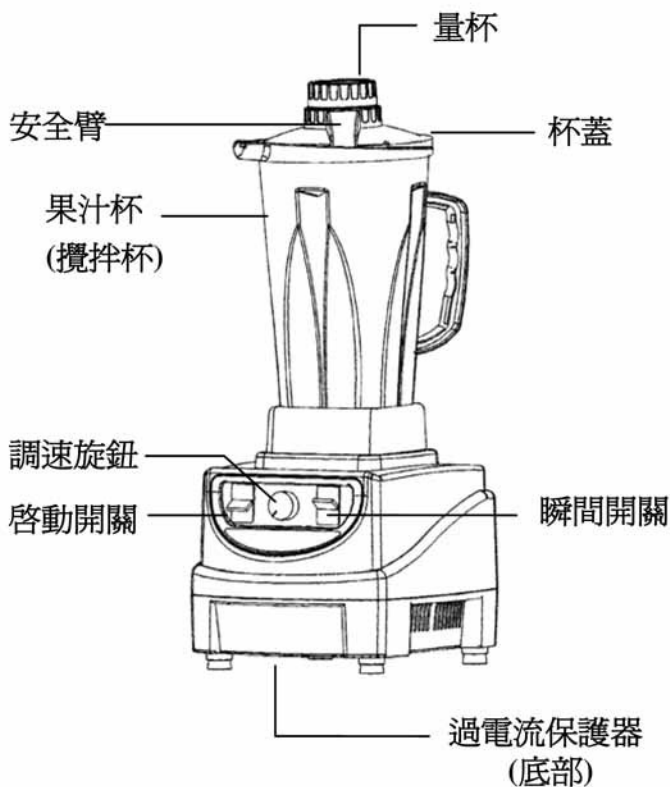

規 格：

電 源：110V/60Hz

消耗電力：1200W

容 量：2000ml

回 轉 數：約 32000RPM

重 量：約 4.8kg

※切勿空機運轉。

安裝方法：

1. 將攪拌杯對準主機放置定位，注意攪拌杯有無與主機上防震墊貼合定位（如圖一）。
2. 將食材放入攪拌杯中，將杯蓋橢圓凸出口對準攪拌杯橢圓嘴口壓入（如圖二），逆時針方向旋入安全臂，聽見卡緊聲爲止；順時針方向旋出安全臂（如圖三），可將杯蓋取出。
3. 啓動開關前，請再確定攪拌杯是否就定位，因本機爲強力馬達，起動瞬間請扶住攪拌杯至機器運轉順暢即可（如圖四）。

安裝圖示：

圖〈一〉

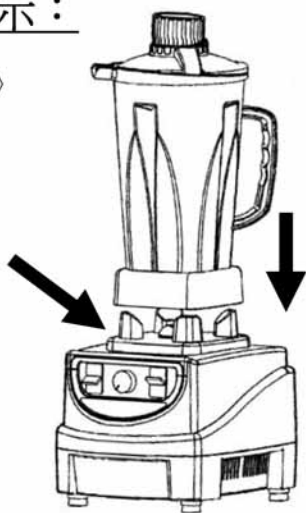

圖〈二〉

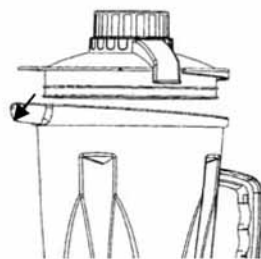

圖〈三〉

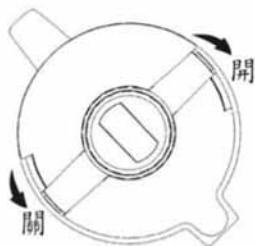

圖〈四〉

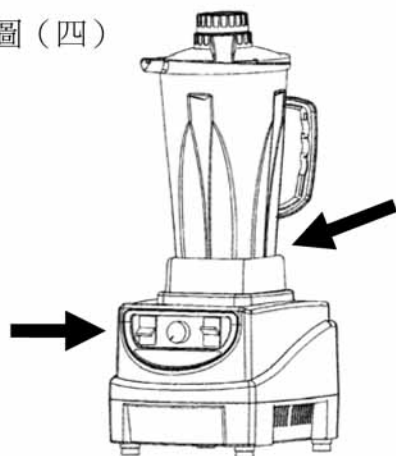

操作模式：

先將電源線插入電源，其操作模式如下：

- A. 手動操作模式：先將調速旋鈕調至“弱”位置，再將啓動開關調至“開”位置，馬達開始運轉，此時可自行調整強弱速度，直至食材攪打完成(連續運轉不超過 1 分鐘)；之後請將按鍵調回至“關”位置，馬達即停止運轉；運轉中欲停止，請將按鍵調至“關”位置，馬達即停止運轉。

- B. 瞬間模式：操作時手按“瞬間”鍵，此時馬達開始以高速運轉，手離開按鍵時，馬達即停止運轉，此模式不可連續運轉 15 秒鐘，每次間隔休息時間為 10 秒鐘。使用瞬間模式請扶住攪拌杯。

- C. 專用攪拌棒：輔助將食材推向工作區，使之能將食材更集中攪打。

面板圖示：

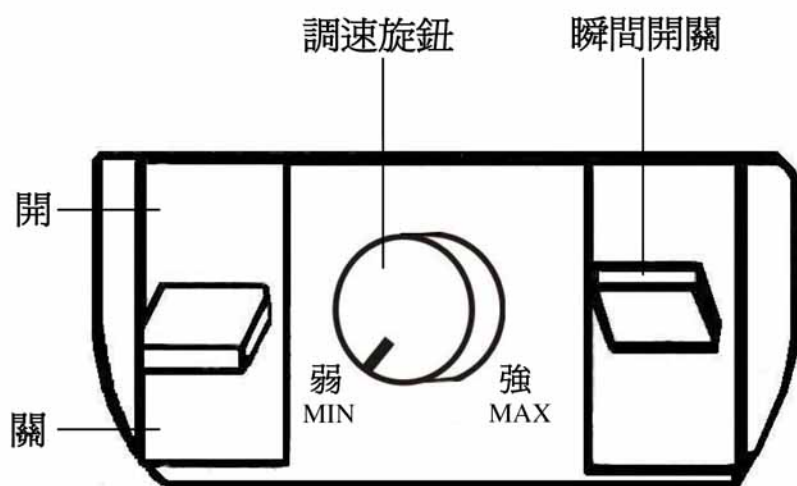

注意事項：

1. 請勿使用於 230V 以外的電源。
2. 使用前請確定攪拌杯及杯蓋是否有正確安裝於機座上。
3. 需靜待調理刀停止運轉時，才可打開杯蓋。
4. 馬達有溫控裝置，若有超負荷使用時，會自動停止運轉，需等馬達降溫後(約 20 分鐘)，底部有一個重置按鈕(恢復型保險絲)按下即可恢復正常使用。
5. 不使用或使用完畢後請將插頭拔除。
6. 裝卸插頭時請確實握住插頭處，切忌直接拉扯電源線，電源線如有破損，請停止使用。
7. 請勿將主體接觸高溫表面或在不平的台面上操作。
8. 運轉中請勿任意搖晃或移動主體。
9. 若電源線損壞時，除公司技術維修人員外，請勿自行動手拆解、修理或改造，以免造成危險。
10. 請勿把如刀、叉、匙等物品放入攪拌杯內以免造成損壞。
11. 勿將本機器用來處理非常堅硬的食物，如冰糖、桃子、多籽食物等。
12. 本機並非設計予弱能人士或兒童使用，或必須由專人看管指導才可使用。

※ 緊急處理方法：

使用中如發生冒煙、起火燃燒情形時，請盡速將插頭拔離，並通知維修中心處理。

保養事項：

1. 馬達機身請用布沾濕擦拭乾淨，請勿浸泡於水中或用水沖洗。
2. 攪拌杯若有異味，用清水加一小片檸檬，裝至主機攪拌 1~3 秒鐘，攪拌杯就清香如新。
3. 清洗攪拌杯前，請先將攪拌杯從主機上取下，再將攪拌杯沖洗乾淨。
4. 清洗後的攪拌杯，將水倒出後再蓋上果汁杯蓋，並裝至主機，空轉 3 秒鐘，將調理刀的水份全部拋乾，以確保衛生及安全。
* 清洗攪拌杯時，請使用瞬間啟動模式。(請參考操作模式)
5. 本調理刀採用 sus420 特殊鋼刀，使用過後須擦乾，若無拭乾產生水銹亦屬正常。
6. 攪拌杯使用完畢後請馬上清洗及擦乾，未飲用完畢之蔬果汁請另用杯子盛裝，避免蔬果汁殘留在杯內時間過長，使調理刀產生水銹。
7. 清洗時，請使用中性清潔劑，勿用酸鹼性清潔劑清洗，以免造成產品材質的損壞。

使用須知：

1. 攪拌硬質食物或冰塊，請先將蔬果或軟質食物放置杯底，再放入硬質食物或冰塊；若攪拌杯內有硬質食物或冰塊卡住調理刀時請立即關閉電源，先將攪拌杯從主機上取下，並用長匙或筷子攪拌後，再裝入主機重新啓動。
2. 因爲自製冰塊較大，使用時須先剝成小塊或使用商用冰塊最能達到攪拌效果。
3. 多汁的蔬果可以不需加水就可以攪拌成蔬果泥，例如：鳳梨、蕃茄、葡萄..等。
4. 少汁的蔬果需加 200cc~300cc 的水才可以攪拌成蔬果泥，如：紅蘿蔔、蘋果、葉菜類..等。
5. 調製生機飲食時，蔬果不能放太多，約攪拌杯的一半，再加入 200cc~300cc 的水，攪拌成蔬果泥後再加水稀釋，就是可口健康的纖維生機飲食。
6. 攪拌冰沙時，請使用瞬間啓動模式。

NAME



STICK

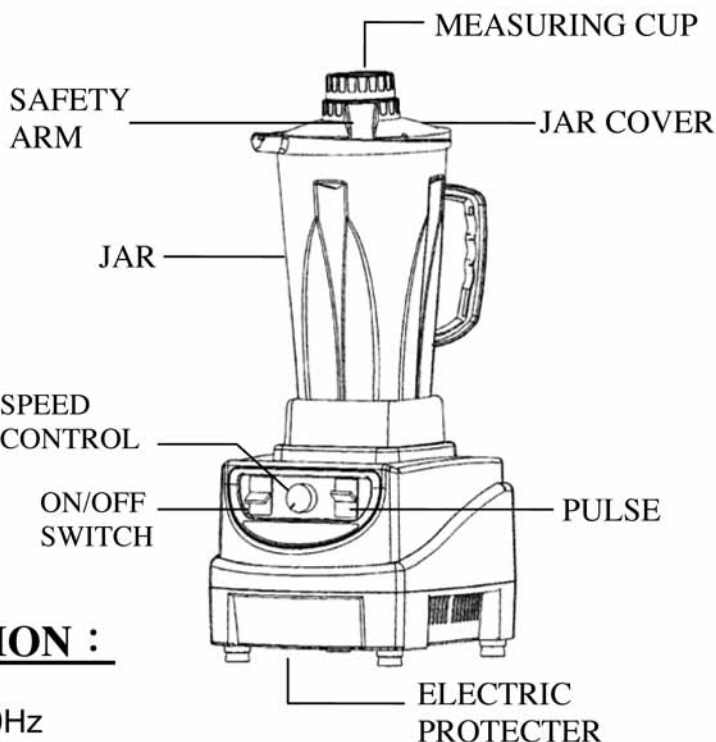

SPECIFICATION :

Voltage : 230V~50Hz

Power : 850W

Capacity : 2.0L

Revolutions : 32000RPM(Approximately)

Weight : 4.8kgs(Approximately)

INSTRUCTION MANUAL

Thank you for choosing Ladyship LVT-866 Nutrition Reserved Food Processor. For safe and proper use of your LVT-866 Nutrition Reserved Food Processor, please read the instruction manual before use.

ASSEMBLY

1. Place the jar onto the motor base. (Picture 1)
2. Make sure the jar and jar cover are located correctly after placing ingredients in the jar. (Picture 2). Turn the safety arm anti-clockwisely until hear a “click” sound to make sure the jar cover is locked. Turn the safety arm clockwise to release the jar cover. (Picture 3)
3. Make sure the jar is in correct position before switching on the unit. This product is with high power motor and please grasp the jar tightly when you turn on unit until the motor runs smooth. (Picture 4)

OPERATION

(Picture 1)

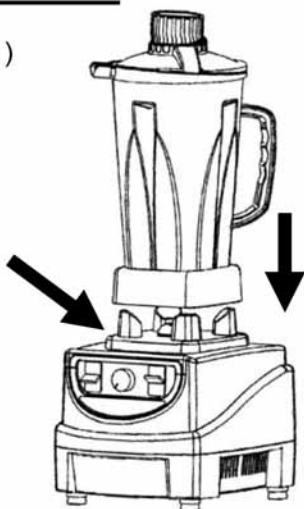

(Picture 2)

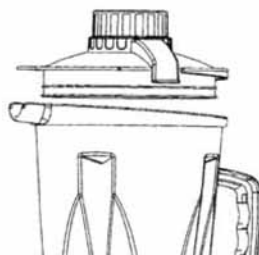

(Picture 3)

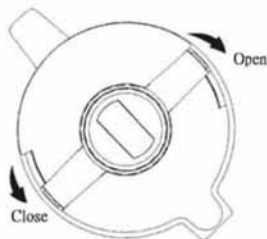

(Picture 4)

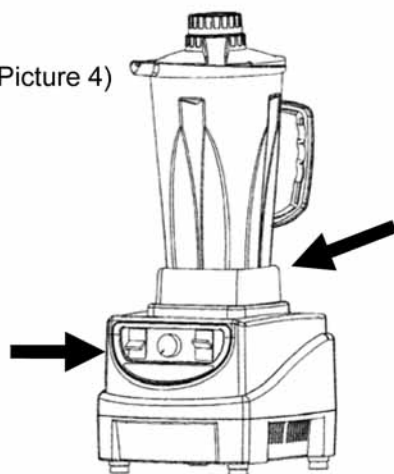

OPERATION

Please plug in the unit and follow the instructions below:

- A. Variable Speed : Please adjust the Speed Control to “Min”. Then turn the On/Off Switch to “ON”, the motor will start operating. You can adjust the desired speed during operation by turning the Speed Control until the blending is finished. (Do not operate longer than 1 minutes); Turn the On/Off Switch to “OFF” and then the power will stop immediately.
- B. Pulse Button : When you hold down the “Pulse” button, the motor will start to operate and when your finger leaves the “Pulse” button, the motor will stop. The Pulse button has been designed for 15 seconds burst only. Please take rest for 10 seconds until next use. For longer blending / juicing periods use the Speed Control.
- C. Stick : Use the Stick to stir the food during operation. This make sure the food can be blended.

CONTROL PANEL

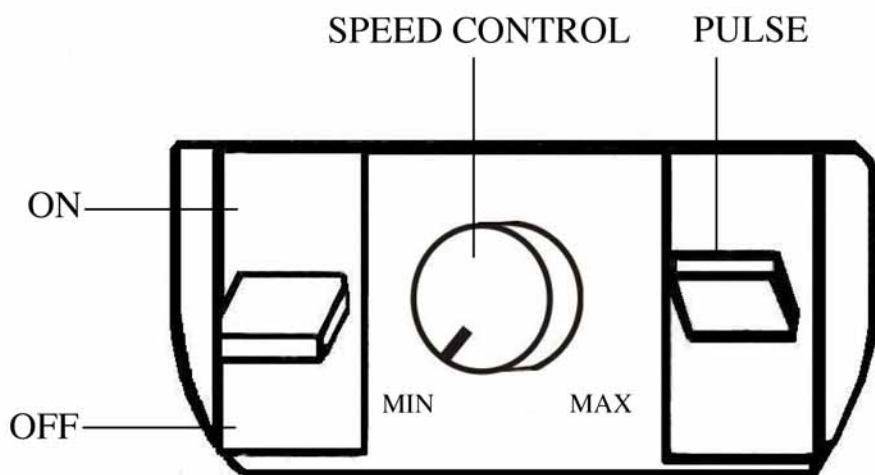

IMPORTANT SAFEGUARDS

1. This unit is intended to be plugged into a 230V outlet only.
2. Make sure the jar and jar cover are in correct position before turning on the unit.
3. Do not remove jar from the motor or open jar cover until blade has stopped completely.
4. This unit is fitted with a temperature control safety switch. If after long or rigorous use, the unit suddenly stops. Disconnect the unit from the power. Allow the unit to cool down around 20 minutes. Then remove the jar from the unit, carefully turn it upside down or on it's side and push the Reset button (on the bottom). If the unit fails to start, leave for a longer period then repeat the procedure. If the unit still does not operate, call the Service Centre for support.
5. Switch off the power and remove the plug when the unit is not in use.
6. Do not operate the unit with a damaged cord or plug; if the unit malfunctions; or if it is dropped or damaged in any manner.
7. Do not attempt to use this unit on an uneven or unstable surface and do not use this unit in high temperature areas.
8. Do not shake or move this unit while it is operating.
9. If the supply cord is damaged; or the unit is defective in any way, it must be replaced or repaired by the Service Centre in order to avoid a hazard.
10. Do not insert or allow foreign objects, such as knives, forks, spoons, etc. to enter the jar as this may case damage to the unit or person's in the vicinity.
11. Do not insert hard food e.g. crustal sugar, peach or food with many seeds.
12. This unit is not intended for use by persons (including children) with reduced physical, sensory or mental capabilities, or lack of experience and knowledge, unless they have been given supervision or instruction concerning use of the appliance by a person responsible for their safety.

※EMERGENCY:

If the unit starts smoking or burning, disconnect from the power source immediately, then contact the Service Centre.

MAINTENANCE AND CLEANING

1. To clean the motor body, wipe with a slightly damp cloth only and DO NOT place the motor base in water.
2. If the jar smells badly: chop up one whole lemon, add some water and blend in the jar for around 1-3 seconds. Allow to stand for a period, rinse out with water and allow to air dry.
3. Please take off the jar from the motor base before you wash the jar.
4. After following the washing instructions, place the jar back on the machine as per normal operation and turn it on for 1 second. This will ensure blades being dried.
5. The blade is made of SUS420; please keep it dry after you wash it or furring may occur on the blade surface.
6. After blending, DO NOT keep the juice in the jar long or furring may occur on the blade surface.
7. DO NOT wash with acidity / alkaline cleanser. This will prevent the deterioration from the product material.

PROPER USE

1. When placing ingredients into the jar put the soft ingredients in first followed by the denser ingredients; If ice or food sticks to the blade, stop the machine, remove the jar from the base. Remove the food from the jar and blade. After cleaning the jar, replace the food and continue blending / juicing.
2. When combining ice with other ingredients, use small blocks rather than large blocks as this will preserve your machine.
3. For low fiber with much water content fruit, vegetables and leaves; blending / juicing can be done without additional water; eg. watermelon, grapes, tomatoes, etc.
4. For high fiber with less water content fruit, vegetables and leaves; blending / juicing add 200-300ml of water (water should just cover the ingredients), eg. carrots, apples, kale, etc.
5. Please use pulse button for smoothies.



貴夫人®

全營養調理機

NUTRITION RESERVED FOOD PROCESSOR